

**UW**

**UNSTABLE CYLINDRICAL LABELING SYSTEM**

Packaging from 9.5mm to 50mm in diameter  
Speed of 150 products per minute<sup>1</sup>  
Built in stainless steel

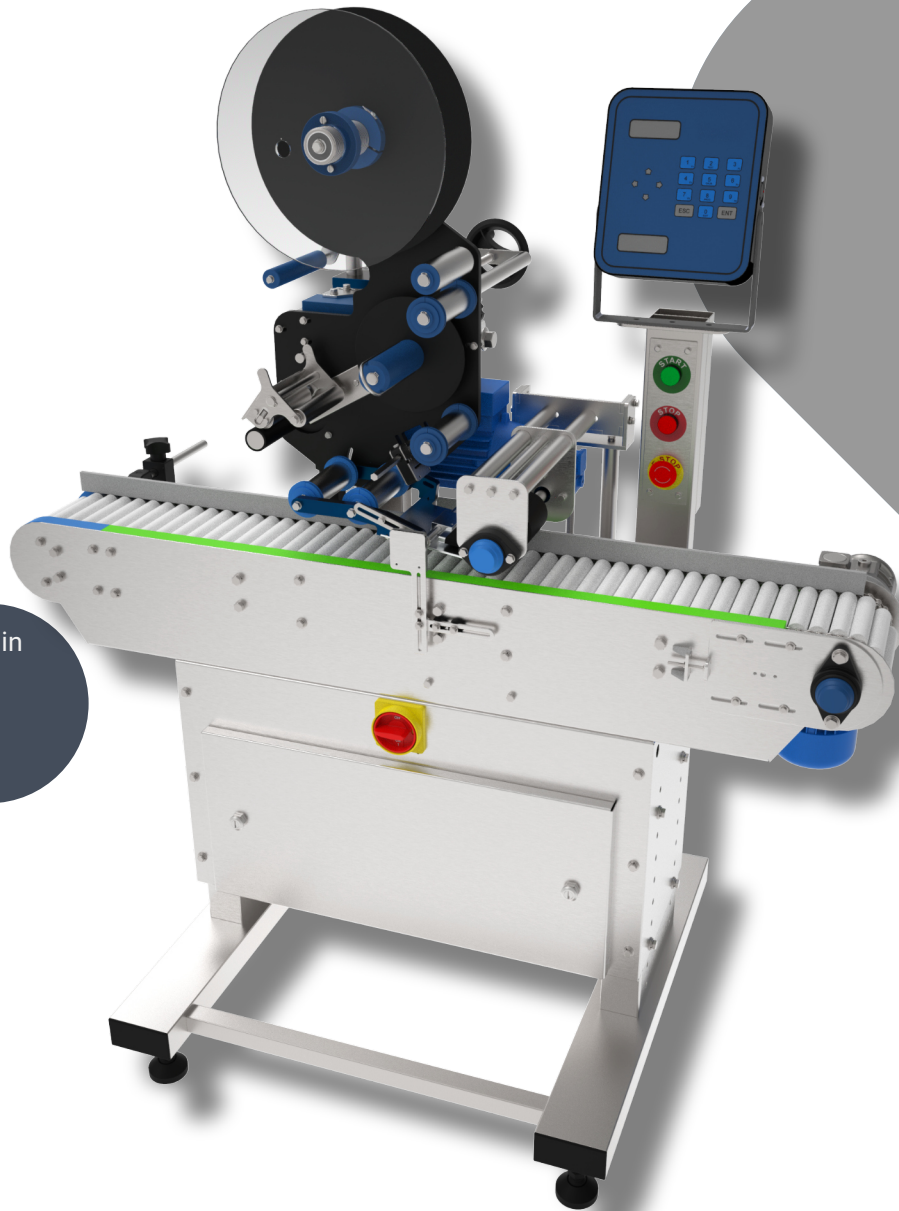

32 product memories  
Numeric keypad with LCD display

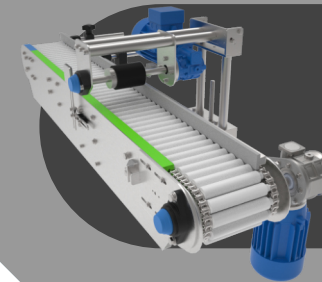

Variable speed with automatic synchronization  
Wrap roller



**KETAN ARGENTINA S.A.**  
Av. Eva Perón 3491, San Martín (1650)  
Buenos Aires - Argentina  
Tel/Fax: (54 11) 5197-8587  
E-mail: [info@ketan.com.ar](mailto:info@ketan.com.ar)

<sup>1</sup> It depends on the size of the container and label.

UW

UNSTABLE CYLINDRICAL  
LABELING SYSTEM

DIMENSIONS



KETAN ARGENTINA S.A.  
Av. Eva Perón 3491, San Martín (1650)  
Buenos Aires - Argentina  
Tel/Fax: (54 11) 5197-8587  
E-mail: info@ketan.com.ar

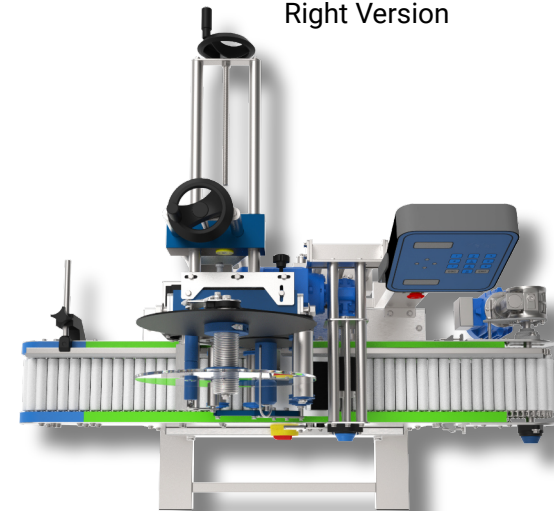
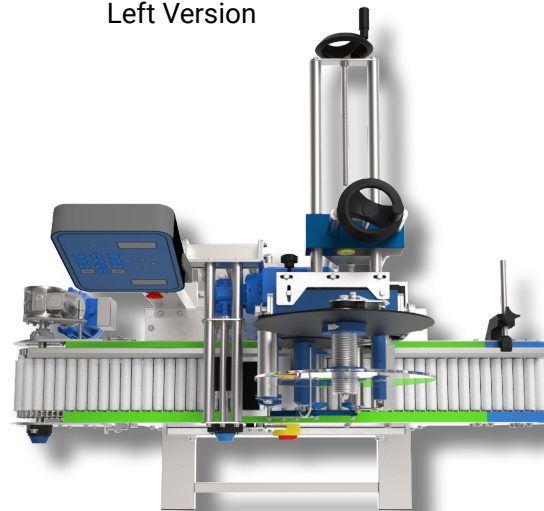
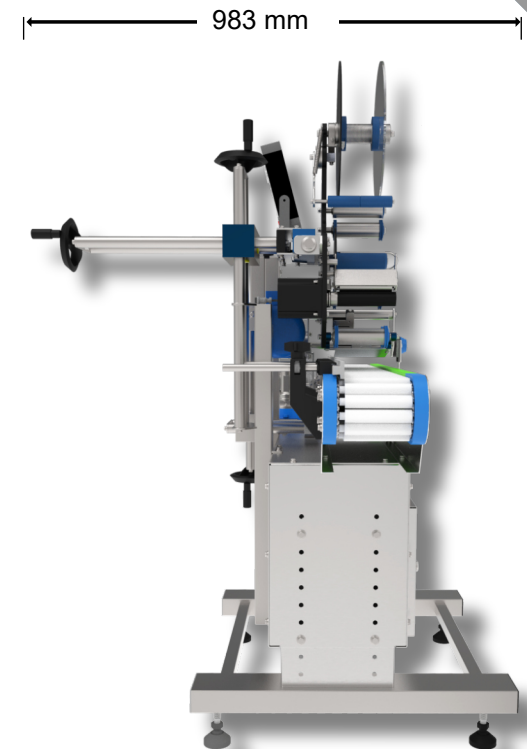
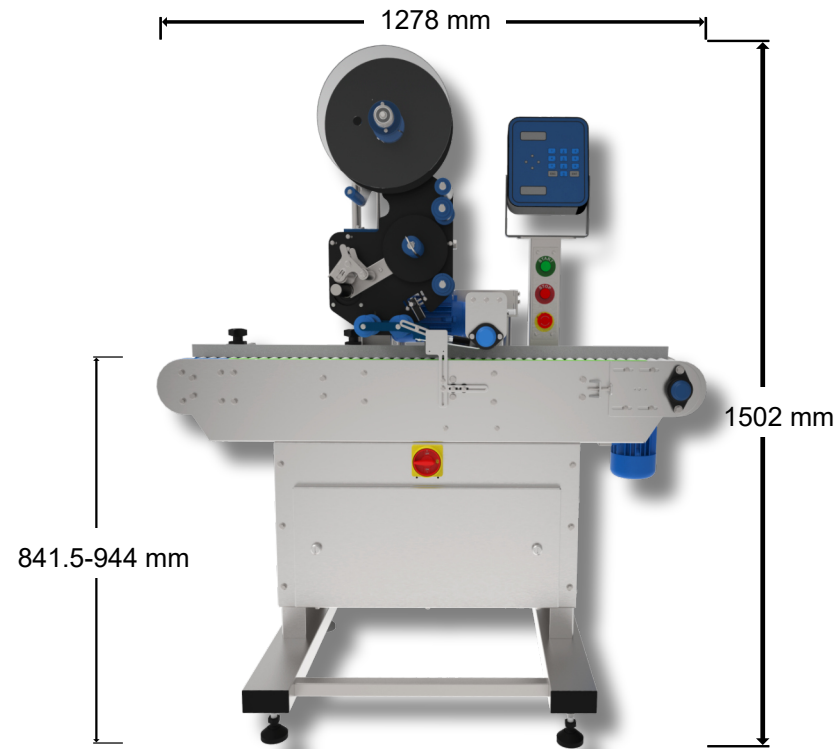

**UW**

UNSTABLE CYLINDRICAL  
LABELING SYSTEM

**SPECS**



**KETAN ARGENTINA S.A.**  
Av. Eva Perón 3491, San Martín (1650)  
Buenos Aires - Argentina  
Tel/Fax: (54 11) 5197-8587  
E-mail: info@ketan.com.ar

<b>Compatible labeling heads</b>	K50, K200, KFLEX
<b>Labeling speed</b>	1-30 m/min
<b>Ancho de etiqueta</b>	Up to 115 or 170 mm depending on the labeling head
<b>Transport width</b>	120 mm standard. Possibility of customized transport widths on request
<b>Paper roll outer diameter</b>	75 mm
<b>Paper roll inner diameter</b>	300 mm
<b>Product diameter</b>	9.5-50 mm
<b>Power supply</b>	1.5 kVA 220V-240V, 50Hz* 110V-120V, 60Hz*
<b>Weight (kg)</b>	200
<b>Dimensions (mm)</b>	1278 x 1502 x 983

\* The equipment is only compatible with one type of electrical supply. You must select the appropriate power supply when placing your order.